

2200 Border Drive Charlotte, NC 28208 Tel. 980-201-3434	Part No: 01	Part Description: Exterior Door Sill Pan Assembly
Project Name:	Provided By:	
Customer Name:	Date:	

Low Pro Sill Pan

Description

Low Pro Sill Pan is an adjustable sill pan flashing designed for exterior doors with ADA compliant thresholds. The sill pan is injection molded with ABS plastic and designed with slope to direct moisture away from areas to prevent water damage from door leaks.

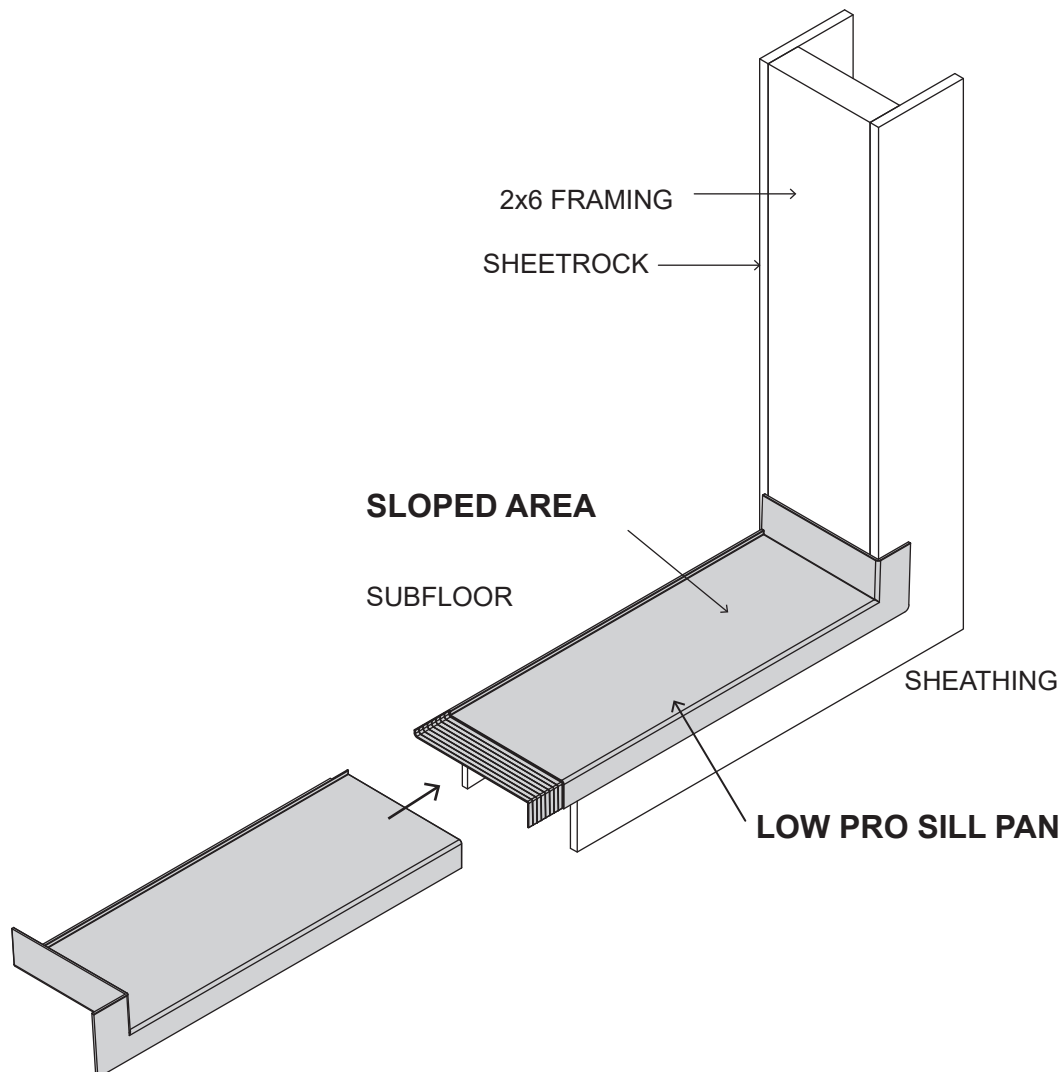

Features

- Adjustable width-Comes with 1/4" premeasured spaces for ease of adjustment
- Sloped design to direct moisture away
- Two piece design with large space for glue
- Glue joint located at the center, away from leak areas
- Ribbed underneath for level application on framing
- Back dam of 3/16"

Overall Dimensions

Exterior Width: 43-1/8" to 42-1/8"

Interior Width: 39-3/8" to 38"

Depth: 7"

Material: ABS

Rockwell Hardness: 112

Tensile Strength: 47 MPa

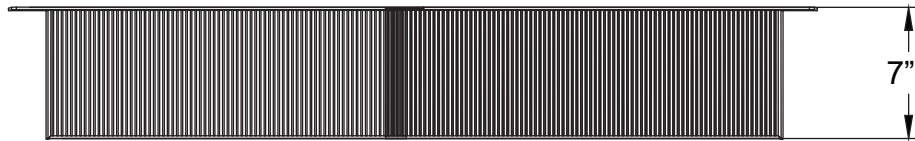
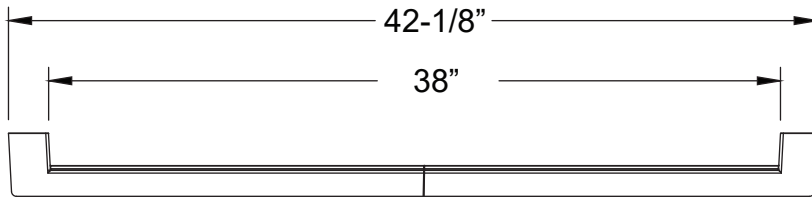
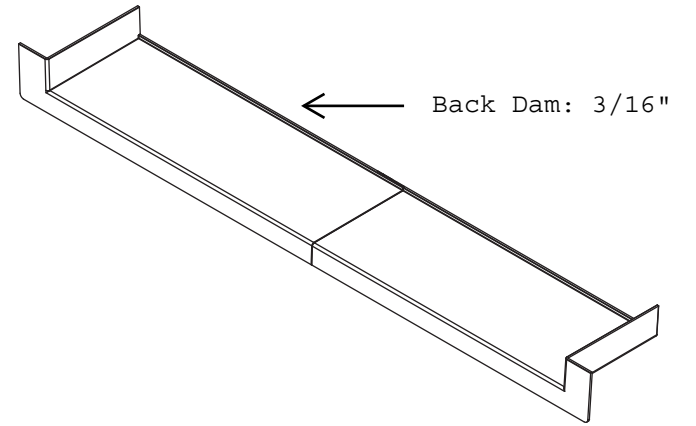
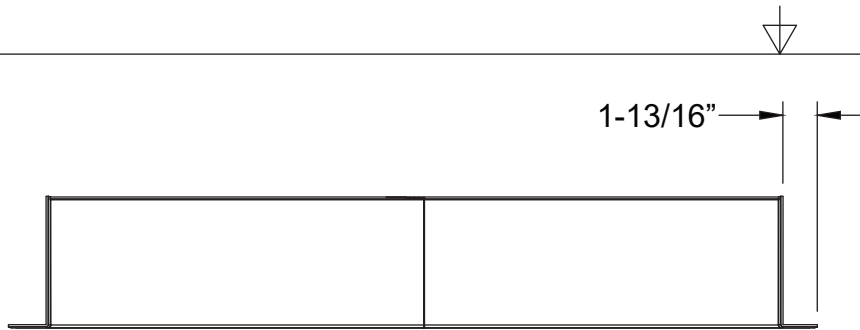

<p>2200 Border Drive, Charlotte, NC 23208 Tel. 980-201-3434</p>	<p>Part No: 01</p>	<p>Part Description: Exterior Door Sill Pan Assembly</p>
<p>Project Name:</p>	<p>Provided By:</p>	
<p>Customer Name:</p>	<p>Date:</p>	

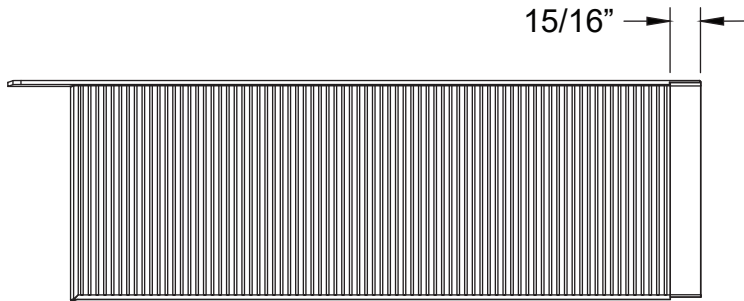
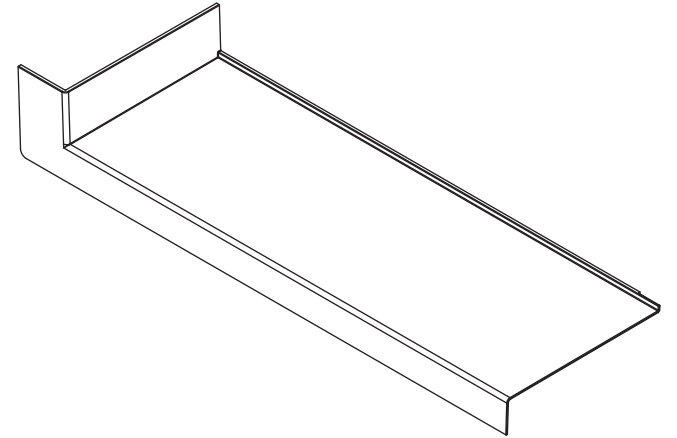
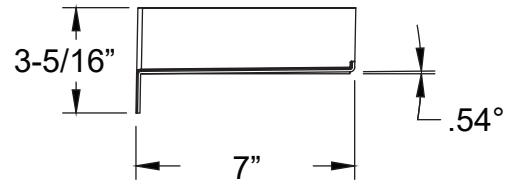
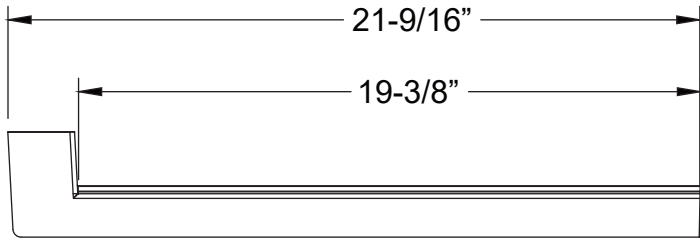
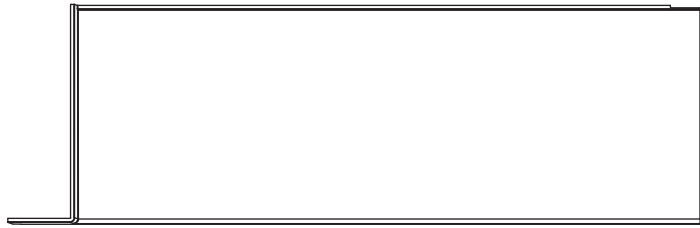

2200 Border Drive Charlotte, NC 28208 Tel. 980-201-3434	Part No: 02	Part Description: Exterior Door Sill Pan Upper
Project Name:	Provided By:	
Customer Name:	Date:	

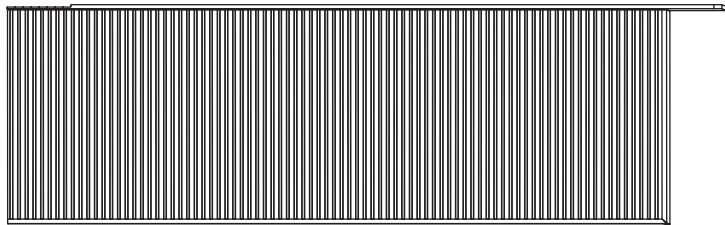
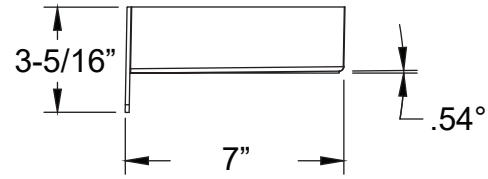
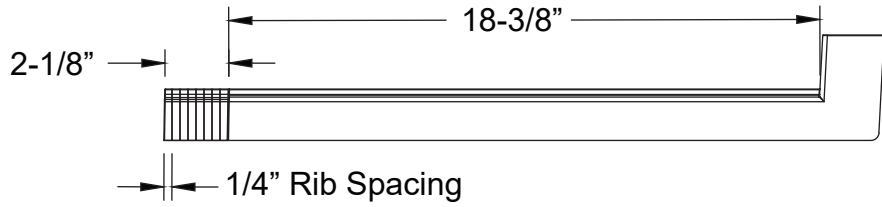
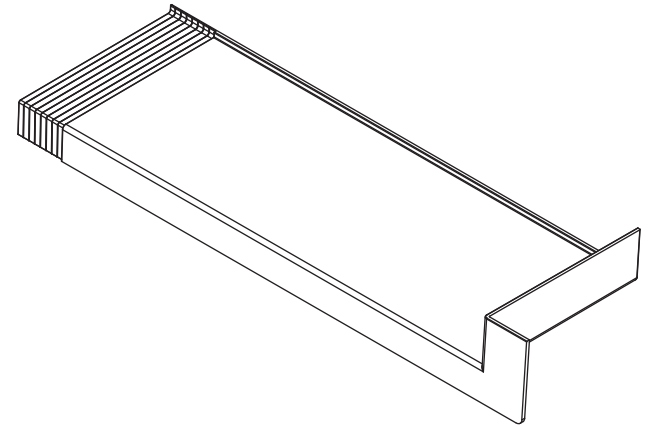
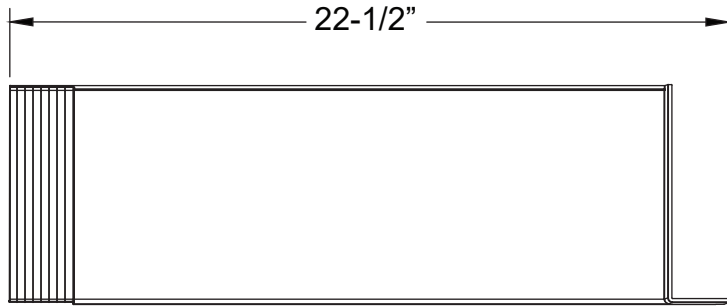

2200 Border Drive Charlotte, NC 28208 Tel. 980-201-3434	Part No: 03	Part Description: Exterior Door Sill Pan Lower
Project Name:	Provided By:	
Customer Name:	Date:	